



Getting Started Sizing and Selecting Servos: Understanding the Need for a System Solution

Sizing and selecting a servo motor system for a machine design begins by understanding the components that make a servo motor or servo-drive system. Servo systems are closed-loop, controlling some desired motion. They incorporate a feedback device that provides constant information between the motor and drive to precisely control position, speed and torque to the mechanism being driven.

Sizing a servo system requires a holistic approach that accounts for global mechanical, electrical and programming parameters. Begin by defining:

- The mechanical load
- The motion profile (including positioning requirements)
- Servo motor characteristics
- The environment in which the motor and other components are placed
- The material being processed and/or the process itself



Mechanical Load and Motion-Profile Parameters

Let's begin with an understanding of the implications of the mechanical load and motion requirements. Basic Newtonian physics asserts that force (or torque in rotary terms) is proportional to the mass (rotary inertia) multiplied by the acceleration rate, whether positive or negative. Within the context of a servo system design, a machine build has its own mass in addition to the mass of the load being transported. It's important to accurately define the masses in motion and their required motion profiles. Mechanisms used to translate rotary motion to linear motion vary widely (Figure A) and depend on the precision, loads, move dynamics and environmental conditions for the application.

Once the mechanism to be used is understood, an understanding of the move dynamics is needed to determine the best servo motor solution. Motion profiles are inclusive of not only the move from one point to another but also what functions might be occurring during that motion, such as thrust forces associated with machining of parts. Acceleration, traverse and deceleration, as well as dwell or rest periods, are included in the overall motion profile of the system. Indexing moves can be simply a triangle move, variable trapezoidal or 1/3-1/3-1/3 (the most efficient move tied to RMS torque).

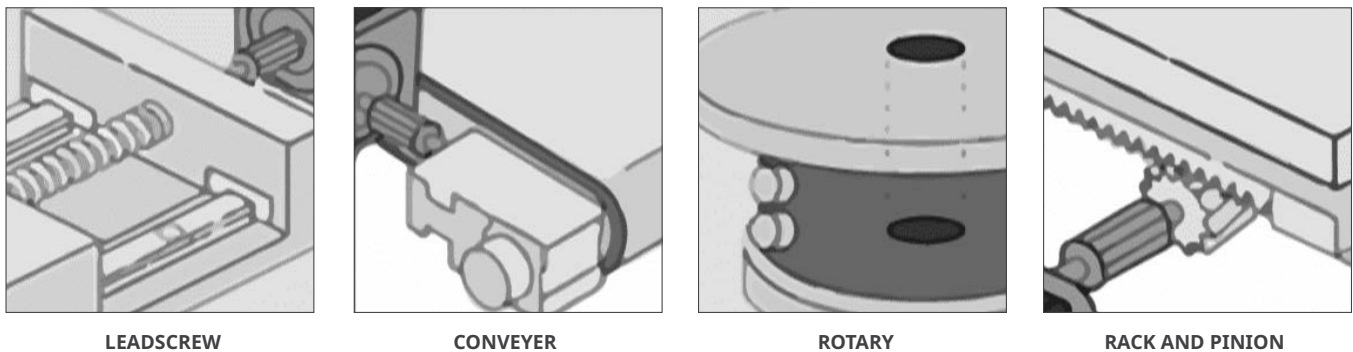

Figure A: Application sizing programs offer various mechanical solution templates

Sizing and selection tools are available to help the user build out a motion profile based on the motion requirements of the application. Most software tools, such as Kollmorgen's Motioneering platform, provide a number of ways to describe a move and assist in calculating acceleration rates, move time and distance, traverse and dwell times.

Figure B shows a basic 1/3-1/3-1/3 profile in Kollmorgen's Motioneering tool with the introduction of 50% jerk to smooth out the acceleration rates. This example shows a move of 8 inches in 1 second using 50% jerk and a dwell of 2 seconds. The system has calculated the move based on 1/3 of the time accelerating, 1/3 at traverse and 1/3 deceleration. Maximum speed was calculated by the tool at 720 in/min. You can see the "S" curve profile (based on the 50% jerk rate).

The thrust load (red line) for this move was applied during the traverse portion of the move — this is where machining may be taking place for the profile. The dwell period runs out to the 3 second mark and is quite important, as all parameters related to this profile will be utilized to calculate the RMS torque.

RMS torque is used when sizing and selecting the correct servo motor. The components in motion must have their inertias summed and reflected back to the motor shaft. In addition to the inertia, external forces, as well as friction and inefficiencies must be taken into consideration.

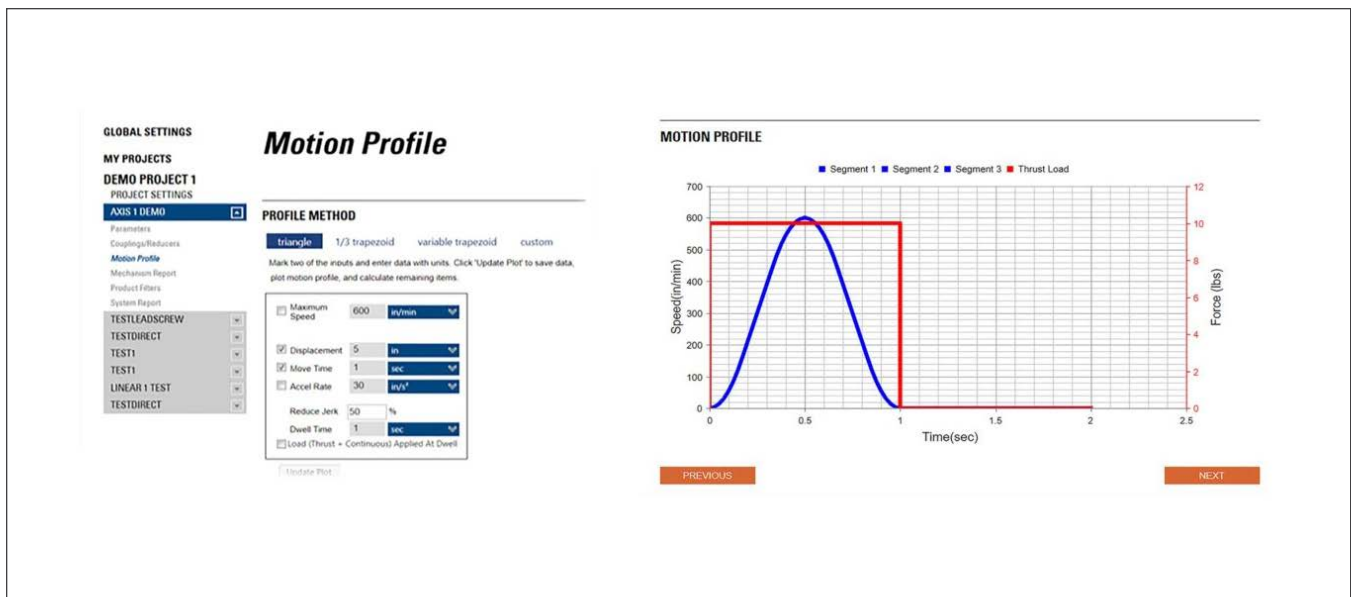

Figure B: Motion profile output of an application sizing program

Unless the design can utilize a direct-drive motor solution, it will include a mechanical transmission of some type. The rotary-to-linear power transmission (to transmute rotary motor output into axis strokes) might be through a pulley-driven belt or screw-based mechanism such as a ballscrew, for example. Rotary transmissions include gearboxes or belt-driven assemblies to function as speed reducers using pulleys of various sizes. In some applications, parts being moved make a significant contribution to the total moving mass. One special case is when a machine axis must move a changing mass—as in the case of robotic systems in dispensing or machining, for example. Here, the total load change can be a factor in tuning the servo drive.

A good portion of the upfront sizing effort in determining the motor/drive system muscle required comes from the mechanics and the motion profile. It's also important to understand the actual positioning requirements of the load regarding resolution, accuracy, and repeatability. This is directly affected by the feedback device selection and (more significantly) the mechanical assembly's amount of lost motion in the form of backlash and compliance.

Feedback Considerations and Servo Motor Characteristics

By definition, servo systems have feedback devices that measure velocity, position and other system parameters during operation. Manufacturers may have limited choices, but careful consideration of specific application parameters—including shock loading, positioning accuracy and repeatability—is essential.

Common feedback devices include:

- Resolvers
- Optical encoders
- Sinusoidal encoders
- Hybrid devices

Resolvers tend to excel in harsh environments especially with higher shock loads. Resolvers are rotary transformers consisting of coils of wire wrapped around a core for both the stator and rotor portions. This architecture allows for higher-temperature operation and is much more forgiving of high shock loads as opposed to optical encoders, which likely contain a glass disc element.

Sinusoidal encoders offer high resolution—up to 24 bits and higher—for best positioning accuracy.

Hybrid feedback devices such as Kollmorgen's SFD (Smart Feedback Device) offer the robustness of a resolver with improved resolution capabilities. These devices are based on a resolver with an electric element that interprets the sine and cosine signals and converts them into a high-resolution digital signal that is passed to the servo drive for both velocity and position feedback.

Another feedback choice that depends on the specific application requirements is the need for absolute position feedback versus incremental. In a rotary system, once you complete a 360-degree rotation with a single-turn device, position starts over at zero. A multi-turn absolute encoder allows your system to know where it is, not only within the 360 degrees of a motor's rotation, but also how many times it made a complete turn in either direction up to a given number of turns. Thus, it knows exactly where you are positioned, even when the machine power is turned off and restarted later.

Absolute position feedback may be beneficial in the positioning of tools and other axes, especially at machine start up, enabling you to bypass homing routines and increase production capability. In contrast, a simple incremental encoder identifies where you are in a single turn, but only after finding itself on a power-up cycle—thus, you will not know how many times you completed a cycle, or even your absolute position within 360 degrees of rotation on power-up.

Another encoder type that you may encounter is the capacitive absolute encoder, which relies on magnetic field changes to be interpreted by the digital converter into a position.

Cabling

Servo motors and servo drives are important, but cabling between the two is important as well. Cable flexibility, as defined by the allowable bend radii, is a key consideration. This is especially true for applications where cables travel with the axis, typically in a longitudinal fashion.

Cable parameters such as impedance and voltage drop, combined with the type and signal strength of the feedback device, are key factors in length considerations. Some newer devices available on the market (such as Kollmorgen's SFD, SICK's DSL, Heidenhain's EnDat and Hengstler's BiSS protocols) transmit serial information to the drive at very high rates, which again are affected by length—specifically impedance and signal-to-noise ratios. Cables need to be designed to handle the kinds of signals being generated from these devices.

Another consideration for the motor's power cable length is tied to the high switching frequencies involved in today's PWM drives. The noise is present in the motor power cable, and as the cable gets longer and approaches a half wave length of the frequency riding on the cable, an antenna is created. Antennas like to transmit or receive information (in this case, noise). Excessive noise can cause problems in a high-performance servo system. This is why it is important to use cables developed and tested by the manufacturer.

Know the exact position, even when the machine is restarted

A multiturn absolute encoder allows your system to know where it is, not only within the 360 degrees of a motor's rotation, but also how many times it made a complete turn in either direction.



Figure C: Cable selection always matters for machine performance and precision.

Environmental Considerations for Servo Designs

One consideration that is often overlooked when specifying a servo design is the environment in which the servo system will operate. Most servo motors are rated for operating in 40°C ambient conditions—which is a very warm environment, but typical of many factory and industrial settings.

Drive electronics aren't particularly forgiving of heat, and while they are often rated for a 40°C ambient operating temperature, managing the temperature in which they operate can become a challenge. Often, forced air cooling methods are required in control cabinets to maintain proper ambient conditions (temperature and humidity). Motors, meanwhile, mount or integrate directly into the machine to drive the mechanisms holding the load.

Manufacturers define motor performance in part by the ambient condition in which the motor will operate. Oftentimes, designers assume that a motor is rated for 40°C ambient, but motor specifications may be rated at 25°C. Care is advised when reviewing specifications to understand what ambient is referenced for the published rating. If the ambient temperature where the machine will operate exceeds the rated ambient temperature, the motor won't perform at its rated capability.

Other environmental conditions can threaten the motor paint, seals and other mechanical subcomponents. Dust, dirt, moisture, wash-down spray, hygienic requirements, explosive settings, vacuum environments and radiation all necessitate specialty servo motor features with physical characteristics tailored to the challenge at hand.

Collaborative Engineering Improves Motion System Outcomes

Through collaborative engineering, Kollmorgen can help you select and size the optimum motor, drive and cables for your application. Contact us to discuss your unique application needs and craft the best solution. And try our online self-service design tools, including the powerful Motioneering sizing and selection software, for confident specification of the motion products that best meet your needs.



Ready to move forward?

[Contact Kollmorgen](#) to discuss your needs and goals with a Kollmorgen expert for servo-driven applications.

About Kollmorgen

Kollmorgen, a Regal Rexnord Brand, has more than 100 years of motion experience, proven in the industry's highest-performing, most reliable motors, drives, AGV control solutions and automation platforms. We deliver breakthrough solutions that are unmatched in performance, reliability and ease of use, giving machine builders an irrefutable marketplace advantage.